

## Energy Consumption in Manufacturing Different Types of Feeds

Dabbour, M., Bahnasawy, A., Ali, S. and Z. El- Haddad

Agric. Eng. Dept., Faculty of Agric., Benha Univ., Egypt  
E-mail: [adel.bahnasawy@fagr.bu.edu.eg](mailto:adel.bahnasawy@fagr.bu.edu.eg)

### Abstract

The determination of the energy consumption in manufacturing different type of feeds, rabbit, poultry and large animal feeds (pellets and crushed), was the main aim of this study. This was achieved by determining the energy consumed in each stage of processing to assess the most consumable stage in the different types of feed. The results indicated that the total specific energy consumed were 243.55, 217.25 and 100.67 kJ/kg for rabbits, poultry and large animals feed pellets, respectively. The crushed feed processing consumed less energy where it was 30.70 and 30.82 kJ/kg for large animals and poultry, respectively. In comparison between the specific energy consumption of different types of feeds, it could be concluded that to produce one kg of rabbit feed pellets consumed energy as 2.43 times as of large animals feed pellets and 8 times as of the energy consumed of crushed feed of large animals. It is worth to mention that pelletizing process was the most consumable stage of feed manufacturing, where, it consumed 80.76, 83.26 and 64.36% of the total energy consumed of rabbits, poultry and large animals feed pellets, respectively.

**Keywords:** Energy, feed manufacturing, feed pellet, pelletization grinding

### Introduction

Energy is one of the most critical input resources in the manufacturing industries. In most cases, energy cost outweighs the costs of other resources such as raw material, labors, depreciation and maintenance (Fadare, 2003). Energy is one of the most important material bases for the economic growth and social development of a country or region. Scientific forecasts and analysis of energy consumption will be of great importance for the planning of energy strategies and policies. Nowadays, energy usage in agriculture has been intensified in response to continued growth of human population, tendency for an overall improved standard of living and limited supply of arable land; thus, the farmers use their inputs in excess and inefficiently, particularly when the inputs have low price or are available in plenty. The enhancement of energy efficiency not only helps in improving competitiveness through cost reduction, also results in minimized energy-related environmental pollution, thus positively contributing towards sustainable development (Kizilaslan, 2009 and Ghorbaniet al., 2010).

Kilbornet al. (1982) found that the total specific milling energy ranged from 46 kJ·kg<sup>-1</sup> for soft wheat cultivars to 124 kJ·kg<sup>-1</sup> for durum wheat. Dziki (2008) reported that the specific grinding energy of uncrushed kernels ranged from 72.3 to 146.7 kJ·kg<sup>-1</sup> and from 67.0 to 114.4 kJ·kg<sup>-1</sup> for Turnia and Slade, respectively. The crushing caused a decrease of specific grinding energy in both cultivars. The total specific grinding energy of crushed kernels (the sum of crushing energy and grinding energy) ranged from 47.6 to 100.5 kJ·kg<sup>-1</sup> and from 44.6 to 85.3 kJ·kg<sup>-1</sup> for hard and soft wheat, respectively. Dziki and Laskowski (2006) presented the results concerning

the influence of grain mechanical properties on wheat grinding energy requirements. The investigations were carried out on 10 wheat varieties (grain moisture was 15%). The results showed that the specific grinding energy ranged from 22 to 37 kJ·kg<sup>-1</sup>. The grinding efficiency index ranged from 0.215 to 0.342 m<sup>2</sup>·kg<sup>-1</sup>.

Kulig and Laskowski (2005) studied the increase in fat concentration in feed material from 2 to 5.5% reduces energy consumption during pelleting by 30%. In general, the specific energy required for pelleting (i.e., energy consumed by the pellet mill motor) may range from 4 to 40 kWh/t (Stevens, 1987; Israelsen et al., 1981 and Tabilet et al., 1997). In addition, steam conditioning/preheating the feed may require considerable energy. For example, Skochet al. (1981) estimated that steam conditioning to increase the temperature from 27 to 80 °C consumed about 26 kWh/t. Steam add in its pelleting operations improves pellet durability. Added steam provides heat and moisture and it also helps to reduce energy consumption during pelleting.

There is no known report in the literature on the energy requirements of feed processing operations as practiced in Egypt. Such information is vital so as to enable the management of this industry to develop strategies for better control of their production operations and modify areas of waste. It will also enable the management to properly appraise their energy consumption for effective planning of production network. The study will provide an opportunity for having a reliable database concerning consumption of various types of energy by different users in feed processing ventures. It will also provide a firm basis of identifying options for saving energy in feed process operations; therefore, the main aim of the present study is to study and evaluate energy consumption in the concentrated feed manufacturing

## Materials and Methods

The main experiment was carried out at the Feed Manufacturing Plant, Faculty of Agriculture, Moshtohor, Benha University, during the period of 2012-2013 to evaluate of energy consumption in the concentrated feeds manufacturing.

### Materials

#### Raw materials used in feed manufacturing:

The feed ingredients of these recipes are shown in Table 1.

**Table 1.** Feed ingredients of three feed pellets.

Ingredients	Large animals feeds	Rabbit feeds	Poultry feed
Yellow corn (9% protein), %	40	13	70
Soybean meal (44% protein), %	10	24	10
Hay (15% protein), %	-	21	-
Wheat bran (11% protein), %	40	19	10
Barley (10% protein), %	-	23	-
Cotton seed meal (41% protein), %	10	-	-
Feed additives, %	-	-	10

### The specific energy consumption

The total energy consumption (electrical and human) for each component was calculated for the production of finished feed manufacturing for both crushed and pelletized feeds. The procedures were used:

Electrical power consumption was estimated from the measured electric current and voltage values and estimated according to Kurt (1979) as follows from equation:

$$Ep = \frac{\sqrt{3} * I * V * \eta * \cos \phi}{1000} \quad (1)$$

Where:

Ep: electrical power, kW, I: electric current, Amperes.

$\eta$ : Mechanical efficiency assumed to be 0.95 (Metwally, 2010).

V: electrical voltage, V,  $\cos \phi$ : Power factors being equal to (0.84).

According to Odigboh (1997), at the maximum continuous energy consumption rate of 0.30 kW and conversion efficiency of 25%, the physical power output of a normal human labor in tropical climates is approximately 0.075 kW sustained for an 8–10 h workday. This was calculated mathematically as:

$$Em = 0.075 N \quad (2)$$

Where:

Em: Human power, kW, N: The number of persons involved in an operation.

Machine productivity was determined by dividing product mass by time, Mg/h.

The specific energy consumption (kJ/kg) was calculated by using the following equation:

$$= \frac{\text{The specific energy consumption}}{\text{Total energy consumption}} = \frac{\text{Productivity}}{\text{Productivity}} \quad (3)$$

## Feed manufacturing plant description

The main components of the feed manufacturing plant are: screw conveyors, hammer mill, horizontal mixer and pelletizer as shown in Fig 1.

### Measurements and devices

The power requirement (kW) was determined by recording the voltage and current strength by using the clamp meter (made in China, Model DT266, Measuring range 200/1000A and 750/1000V with an accuracy of  $\pm 0.01$ ) to measure the line current strength (I) and the potential difference value (V).

## Results and Discussions

### 1. Energy Consumed in Feed Manufacturing

#### 1.1. Pelleted feeds

Table 2 shows the energy consumed in manufacturing rabbits, poultry and large animal feed pellets and Figs from 2 to 5 show the energy flow diagram and percentages of energy consumption in manufacturing rabbits, poultry and large animals feed pellets.

For rabbits feed pellet, it could be seen that, the total energy consumed is divided into two types, namely, electrical and human energies. The results indicated that the total energy consumed was 243.55 kJ/kg of feed. The human energy required for making rabbit feeds pellets ranged from 0.04 to 0.47 kJ/kg, where, the electrical energy consumed ranged from 0.41 to 196.71 kJ/kg of feed. There are eleven handling stages starting at the milled corn storage tank ( $H_1$ ) to the packaging stage ( $H_{11}$ ), they consumed a total of 26.38 kJ/kg which represents 10.83% of the total energy consumption. Corn grinding process consumed 12.59 kJ/kg which represents 5.17% of the total energy consumption. The energy consumed in the mixing process was 6.91 kJ/kg, which represents 2.84% of the total energy consumption. The specific energy consumed in the pelletization process was 196.71 kJ/kg which is considered the highest rate in the consumption of electrical energy in the manufacturing process and represented 80.76% of the total energy consumed in manufacturing.

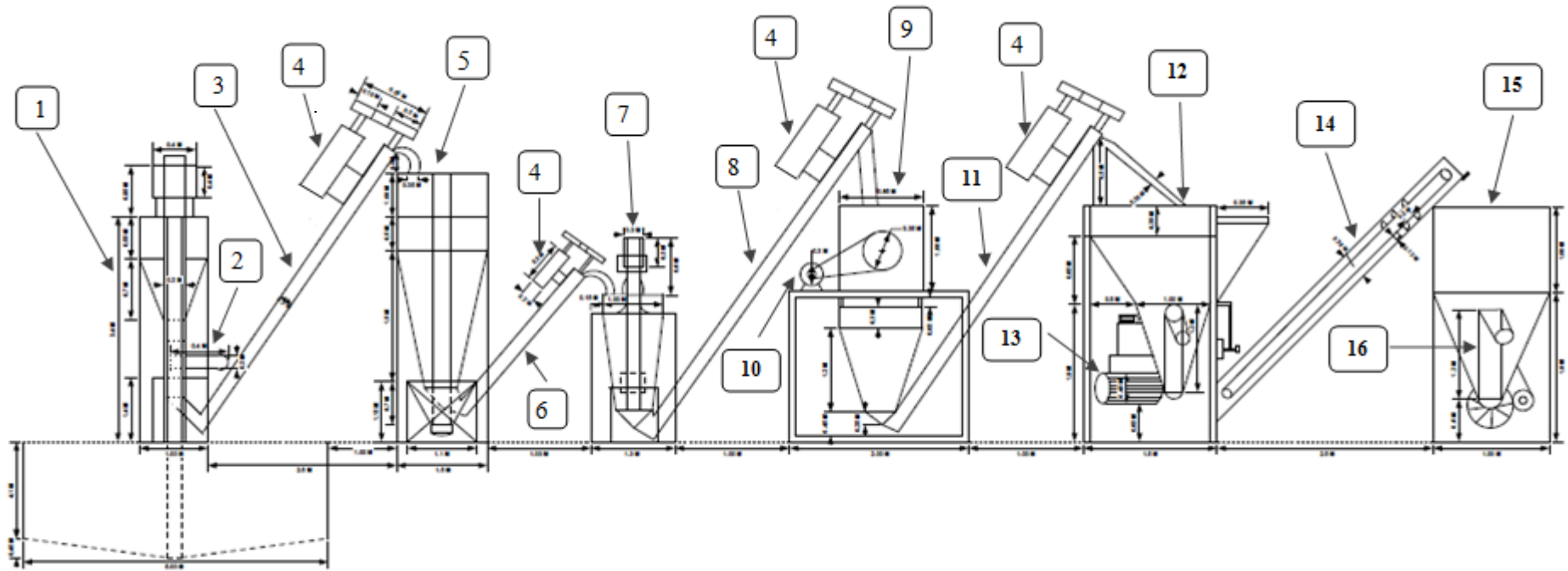

- |   |   |
|---|---|
| 1- Hammer mill.   | 9- The mixer.   |
| 2- Mill motor.  | 10- Mixer motor.  |
| 3- Screw conveyor (transport crushed corn to the corn tank).                      | 11- Screw conveyors (conveying to the pellet mill of tank). |
| 4- Screw conveyor motor.  | 12-The pelletizer.  |
| 5- Corn and soybean tank.   | 13- Motor of pelletizer.                                    |
| 6- Screw conveyor (transport soybean and crushed corn to the weighing unit tank). | 14- Belt conveyor.  |
| 7- Weighing and proportioning unite.  | 15- Final product tank.                                     |
| 8- Screw conveyor (conveying to the mixer).                                       | 16- Packaging Screw.  |

**Fig. 1:** Schematic diagram of the components of feed manufacturing plant.

**Table 2.** The specific energy consumed in manufacturing rabbits, poultry and large animals feed pellets.

Process sequences	Process	Total energy consumed, kJ/kg			% of total energy consumed		
		Rabbits feed	Poultry feed	Large animals feed	Rabbits feed	Poultry feed	Large animals feed
1	Raw materials receiving	0.05	0.05	0.05	0.02	0.02	0.05
2	Handling stage 1 (corn from storage tank to the mill, H <sub>1</sub> )	3.43	3.43	3.43	1.41	1.58	3.41
3	Grinding	12.59	12.59	12.59	5.17	5.80	12.51
4	Handling stage 2 (crushed corn to the corn tank, H <sub>2</sub> )	5.75	5.75	5.75	2.36	2.65	5.71
5	Handling stage 3 (crushed corn to the weighing unit tank, H <sub>3</sub> )	0.49	0.49	0.49	0.20	0.23	0.49
6	Handling stage 4 (soybean to the soybean tank, H <sub>4</sub> )	0.95	0.95	0.95	0.39	0.44	0.94
7	Handling stage 5 (soybean to the weighing unit tank, H <sub>5</sub> )	0.57	0.57	0.52	0.24	0.26	0.52
8	Handling stage 6 (to the weighing unit tank, H <sub>6</sub> )	0.91	0.71	0.86	0.37	0.33	0.85
9	Handling stage 7 (to the mixer, H <sub>7</sub> )	0.90	0.66	0.67	0.37	0.30	0.67
10	Mixing	6.91	3.85	5.93	2.84	1.77	5.89
11	Handling stage 8 (to the pellet mill of tank, H <sub>8</sub> )	5.93	0.78	1.14	2.43	0.36	1.13
12	The feeder (H <sub>9</sub> )	2.02	1.22	0.80	0.83	0.56	0.79
13	Pelletization	196.71	180.88	64.79	80.76	83.26	64.36
14	The cooling	0.59	0.47	0.19	0.25	0.22	0.19
15	Belt conveyor (H <sub>10</sub> )	4.93	4.09	1.58	2.02	1.87	1.57
16	Handling stage 1 (packaging, H <sub>11</sub> )	0.51	0.50	0.60	0.21	0.23	0.60
17	Weighing and sewing	0.27	0.22	0.29	0.11	0.10	0.29
18	Loading	0.04	0.04	0.04	0.02	0.02	0.04
Total		243.55	217.25	100.67	100	100	100

For poultry feed pellets, it could be seen that, the total energy consumed was 217.25 kJ/kg in manufacturing poultry feed. The human energy required for making poultry feeds pellets ranged from 0.04 to 0.22 kJ/kg, where, the electrical energy consumed ranged from 0.40 to 180.88 kJ/kg of feed. Handling consumed a total of 19.15 kJ/kg which represents 8.81% of the total energy consumption. Corn grinding process consumed 12.59 kJ/kg, which represents 5.80% of the total energy consumption. The energy consumed in the mixing process was 3.85 kJ/kg, which represents 1.77% of the total energy consumption. The energy consumed in the pelletization process was 180.88 kJ/kg which represented 83.26% of the total energy consumed in manufacturing.

For large animal feed pellets, it could be seen that, the total specific energy consumption was 100.67 kJ/kg in manufacturing large animals feed. The human energy required for making large animals feed pellets ranged from 0.04 to 0.33 kJ/kg, where, the electrical energy consumed ranged from 0.19 to 64.79 kJ/kg of feed. Corn grinding process consumed

12.59 kJ/kg which represents 12.51% of the total energy consumption. The energy consumed in the mixing process was 5.93 kJ/kg, which represents 5.89% of the total energy consumption. The energy consumed in the pelletization process was 64.79 kJ/kg which represented 64.36% of the total energy consumed in manufacturing.

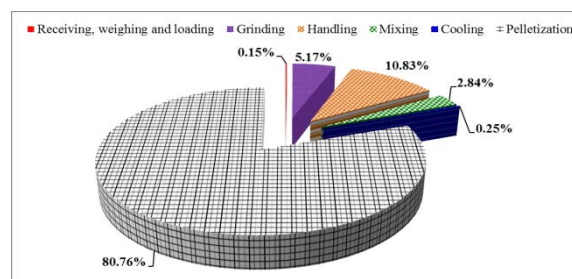
**Fig. 2:** The percentages of energy consumption in manufacturing rabbits feed pellets.

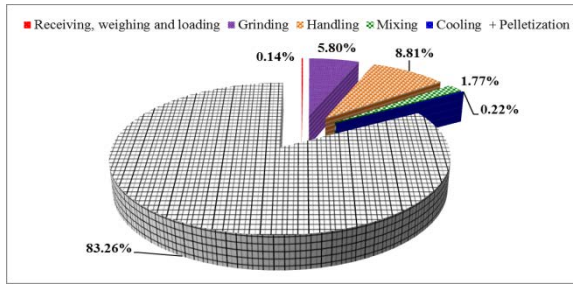

**Fig. 3:** The percentages of energy consumption in manufacturing poultry feed pellets.

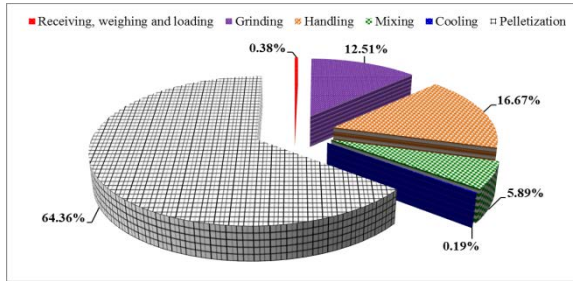

**Fig. 4:** The percentages of energy consumption in manufacturing large animal feed pellets.

**Crushed feeds**

Table 3 shows the energy consumed in manufacturing the crushed feeds of large animal and poultry and Figs from 6 to 8 show the energy flow diagram and percentages of energy consumption in manufacturing large animals and poultry crushed feed.

For large animal crushed feed, it could be seen that, the total energy consumed was 30.70 kJ/kg of feed (crushed). The human energy required for making large animal feed crushed ranged from 0.04 to 0.14 kJ/kg, where, the electrical energy consumed ranged from 0.47 to 12.59 kJ/kg of feed. There are nine handling stages that consumed a total of 14.28 kJ/kg which represent 46.51% of the total energy consumption. Corn grinding process consumed 12.59 kJ/kg which represent 41.01% of the total energy consumption. The energy consumed in the mixing process was 3.60 kJ/kg, which represents 11.73% of the total energy consumption.

For poultry crushed feed, it could be seen that, the total energy consumed was 30.82 kJ/kg in manufacturing poultry feed crushed. The human energy required for making poultry feed crushed ranged from 0.04 to 0.14 kJ/kg, where, the electrical energy consumed ranged from 0.49 to 12.59 kJ/kg of feed. There are nine handling stages that consumed a total of 14.15 kJ/kg which represents 45.92% of the total energy consumption. Corn grinding process consumed 12.59 kJ/kg which represent 40.85% of the total energy consumption. The energy consumed in the mixing process was 3.85 kJ/kg, which represent 12.49% of the total energy consumption.

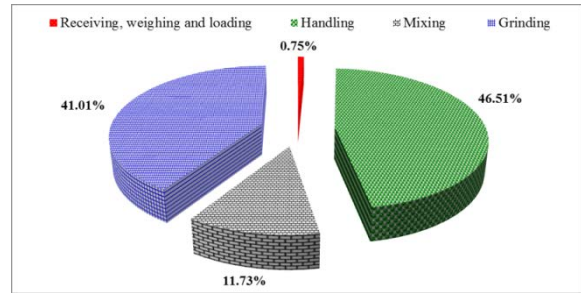

**Fig. 6:** shows the percentages of energy consumption in manufacturing large animal crushed feed.

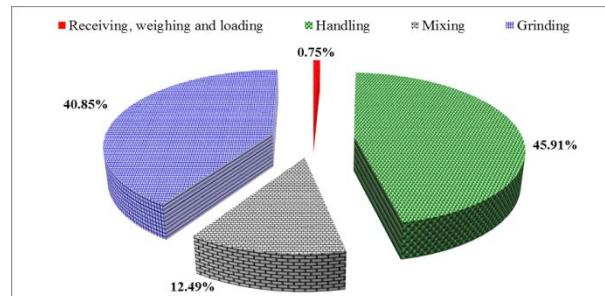

**Fig. 7:** shows the percentages of energy consumption in manufacturing poultry crushed feed.

**Comparison between the specific energy consumption of different types of feeds**

Table 4 and Fig9 and shows the specific energy consumed in manufacturing of different kinds of feeds namely, rabbit, poultry and large animals. It could be seen that the specific energy consumed in manufacturing rabbit feed pellets was 243.55 kJ/kg as compared with 217.25 kJ/kg for poultry feed pellets, while the energy consumed in manufacturing the large animal feed pellets was much lower than that of both rabbit and poultry feed, where it recorded 100.67 and 30.70 kJ/kg for the large animal feed pellets and crushed, respectively. It could be concluded that to produce one kg of rabbit feed pellets consumed energy as 2.43 times as of large animal feed pellets and 8 times as of the energy consumed of crushed feed of large animals. It is worthy to mention that the poultry feed pellets consumed energy in manufacturing 8 times as the poultry crushed feed required.

The Table show also the electrical energy consumed in manufacturing rabbit feed was 241.92 kJ/kg as compared with 216.73 kJ/kg for poultry feed, while the energy consumed in manufacturing the large animal feeds was much lower than that of both rabbit and poultry feed, where it recorded 99.57 and 30.26 kJ/kg for the large animal pellets and crushed feed, respectively. It could be concluded that to produce one kg of rabbit feed consumed energy as 2.43 times as large animal feed pellets and 8 times as the energy consumed of crushed feed of large animal.

The Table shows also the human energy consumed in manufacturing rabbit feed was 1.63 kJ/kg as compared with 0.52 kJ/kg for poultry feed, while the energy consumed in manufacturing the

large animal feed crushed was much lower than that of both rabbit and poultry feed, where it recorded 0.44 kJ/kg for large animal feed crushed. The energy consumed in large animal feed pellets was much higher than that of poultry feed, where it recorded 1.10 kJ/kg for the large animal feed pellets. It could be concluded that to produce one kg of rabbit feed consumed energy as 1.48 times of large animal feed pellets and 3.70 times of the energy consumed of crushed feed of large animal. It worthy to mention that the poultry feed pellets consumed energy in manufacturing 3.13 times as the poultry feed pellets and crushed required.

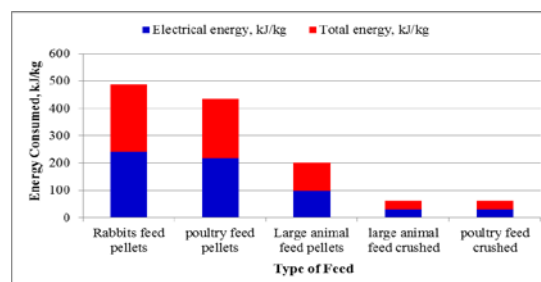

Figure 9: The total and electrical energy consumed in manufacturing different types of feeds.

**Table 3:** The specific energy consumed in manufacturing of large animal and poultry feed (crushed).

Process sequences	Process	Total energy consumed, kJ/kg		% of total energy consumed	
		Large animals feeds	Poultry feeds	Large animals feeds	Poultry feeds
1	Raw materials receiving	0.05	0.05	0.16	0.16
2	Handling stage 1 (corn from storage tank to the mill, H <sub>1</sub> )	3.43	3.43	11.17	11.13
3	Grinding	12.59	12.59	41.01	40.85
4	Handling stage 2 (crushed corn to the corn tank, H <sub>2</sub> )	5.75	5.75	18.73	18.66
5	Handling stage 3 (crushed corn to the weighing unit tank, H <sub>3</sub> )	0.49	0.49	1.60	1.60
6	Handling stage 4 (soybean to the soybean tank, H <sub>4</sub> )	0.95	0.95	3.09	3.08
7	Handling stage 5 (soybean to the weighing unit tank, H <sub>5</sub> )	0.47	0.57	1.53	1.85
8	Handling stage 6 (to the weighing unit tank, H <sub>6</sub> )	0.86	0.71	2.80	2.30
9	Handling stage 7 (to the mixer, H <sub>7</sub> )	0.72	0.66	2.35	2.14
10	Mixing	3.60	3.85	11.73	12.49
11	Handling stage 8 (to the packaging tank, H <sub>8</sub> )	0.81	0.78	2.63	2.53
12	Handling stage 9 (packaging, H <sub>9</sub> )	0.80	0.81	2.61	2.63
13	Weighing and sewing	0.14	0.14	0.46	0.45
14	Loading	0.04	0.04	0.13	0.13
15	Total	30.70	30.82	100	100

**Table 4:** Specific energy consumed in manufacturing of different types of feeds.

Type of feed	Specific energy consumed		Total energy consumption, kJ/kg
	Electrical energy, kJ/kg	Human energy, kJ/kg	
Rabbits feed pellets	241.92	1.63	243.55
Poultry feed pellets	216.73	0.52	217.25
Large animal feed pellets	99.57	1.10	100.67
Large animal crushed feed	30.26	0.44	30.70
Poultry crushed feed	30.38	0.44	30.82

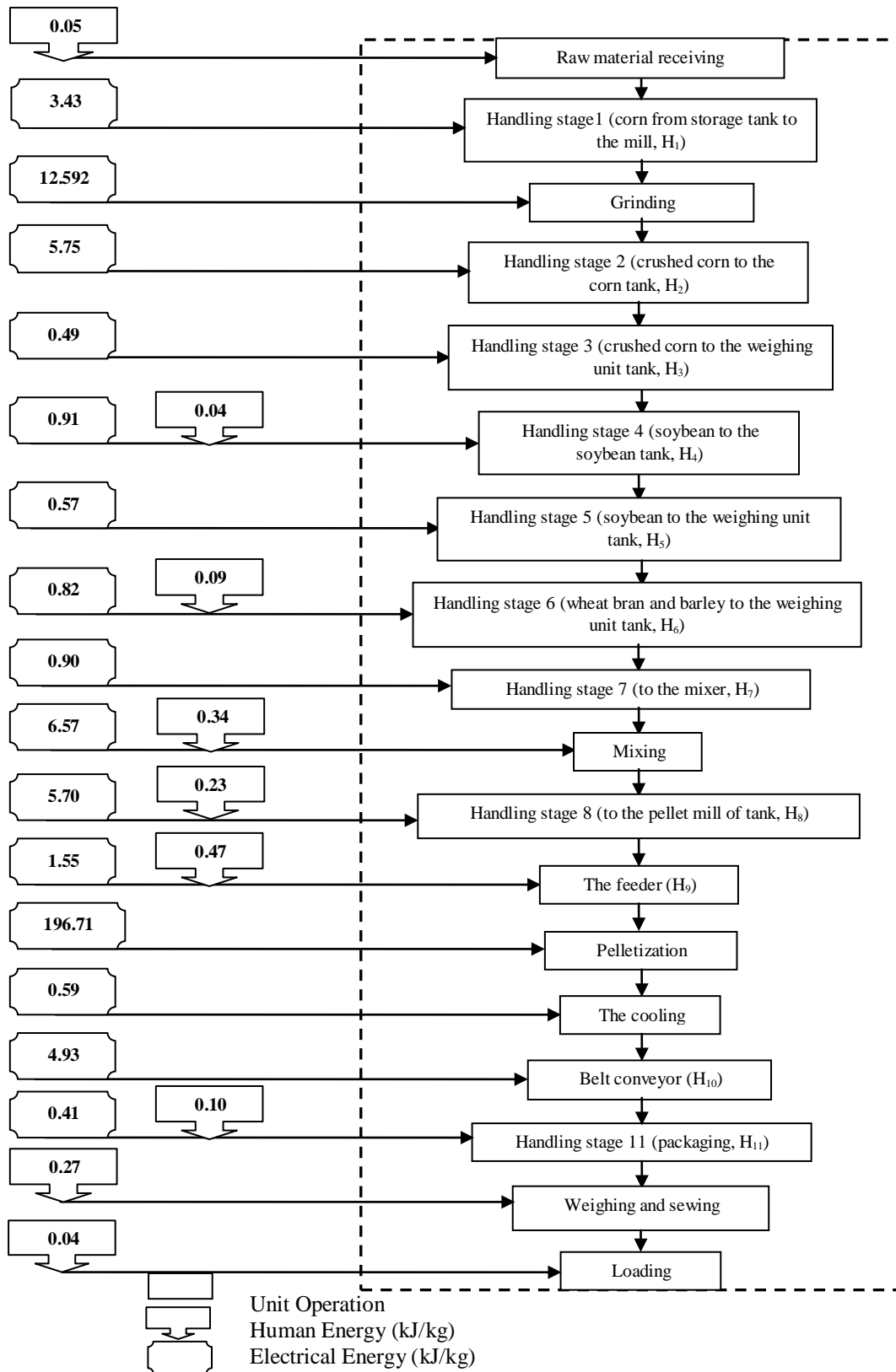
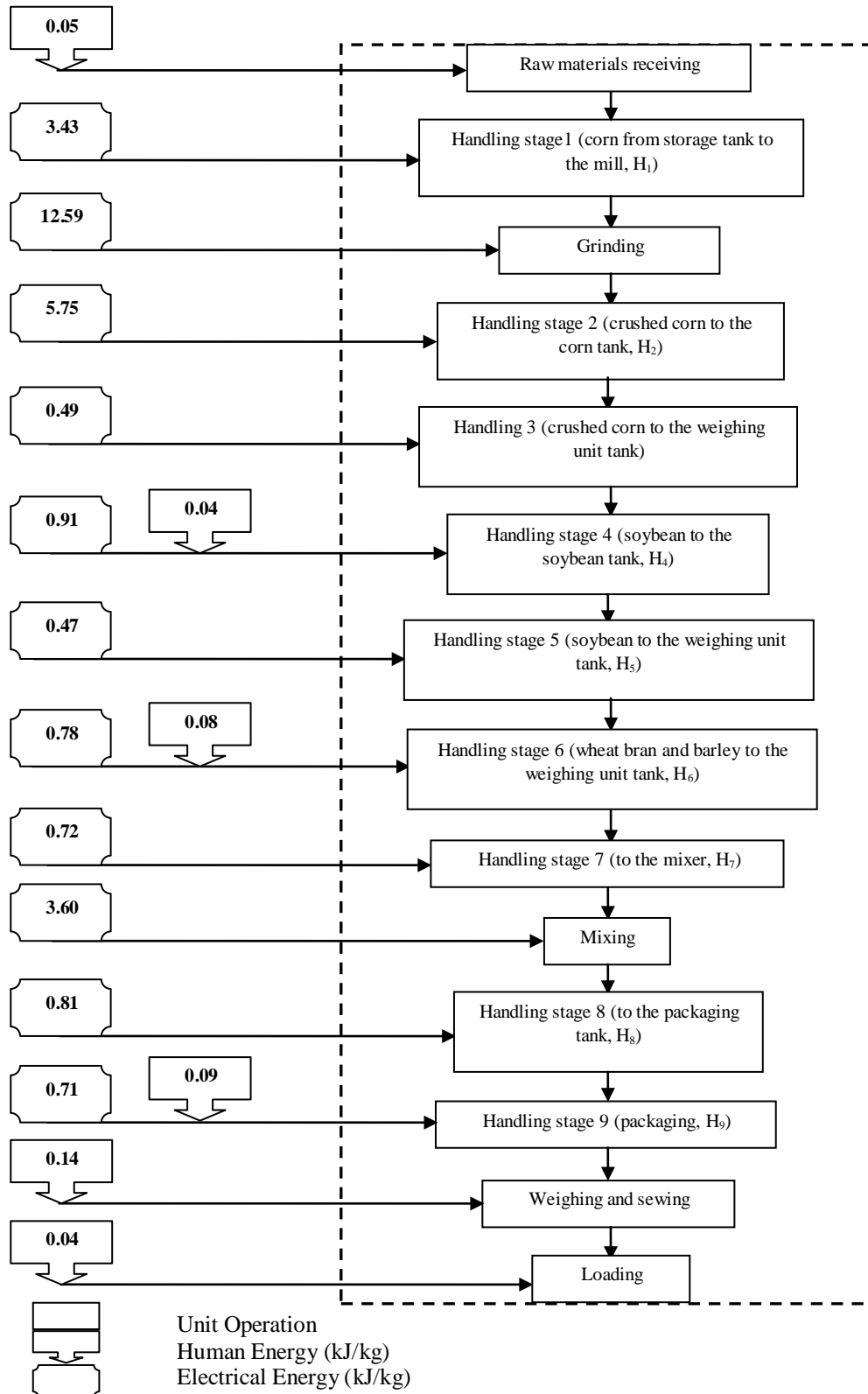

Fig. 5: Energy flow diagram of manufacturing processes of rabbits feed pellets.



**Fig.8:** Energy flow diagram of manufacturing processes of large animal crushed feed.



## Conclusion

Two types of energy were used in feed manufacturing, namely, electrical and human energies. The electrical energy represented the most energy consumed, where, it ranged from 98.90-99.76% of the total energy consumed in feed pellets manufacturing, while it was 98.57% of the total energy consumed in crushed feed manufacturing. Human energy ranged from 0.24- 1.10% of the total energy consumed in feed pellets manufacturing, while it was 1.43% of the total energy consumed in crushed feed manufacturing. Pelletizing process was the most consumable stage in feed pellet manufacturing, where, it represents 80.76, 83.26 and 64.79% of the total energy for rabbits, poultry and large animals feed pellets, respectively. In comparison between the specific energy consumption of different types of feeds, it could be concluded that to produce one kg of rabbit feed pellets consumed energy as 2.43 times as of large animals feed pellets and 8 times as of the energy consumed of crushed feed of large animals. It is worthy to mention that the poultry feed pellets consumed energy in manufacturing 8 times as the poultry crushed feed required.

## References

- Dziki, D. 2008. The crushing of wheat kernels and its consequence on the grinding process. *Powder Technology*, 185: 181– 186.
- Dziki, D. and J. Laskowski. 2006. Influence of wheat grain mechanical properties on grinding energy requirements. *TEKA Kom.Mot.Energ.Roln.*, 6A, 45– 52.
- Fadare, D. A. 2003. Development of an organo-mineral fertilizer processing plant. A Ph.D. thesis of Department of Mechanical Engineering, University of Ibadan. Ibadan, Nigeria.
- Ghorbani, R., F. Mondani, S. Amirmoradi, H. Feizi, S. Khorramdel and M. Teimouri. 2010. A case study of energy use and economical analysis of irrigated and dryland wheat production systems. *Appl Energy*, 88: 283–288.
- Israelsen, M., J. Busk and J. Jensen. 1981. Pelleting properties of dairy compounds with molasses, alkali-treated straw and other byproducts. *Feedstuffs*, 7:26–28.
- Kilborn, R. H., H. C. Black, J. E. Dexter and D. G. Martin. 1982. Energy consumption during flourmilling. Description of two measuring systems and influence of wheat hardness on the energy requirements. *Cereal Chemistry*, 59: 284–288.
- Kizilaslan, H. 2009. Input–output energy analysis of cherries production in Tokat Province of Turkey. *Appl Energy*, 86:1354– 8.
- Kulig R. and J. Laskowski. 2005. Wpływ zawartości tłuszczu na proces granulowania materiałów paszowych. *Inżynieria Rolnicza*, 7(67): 59-68.
- Kurt, G. 1979. *Engineering formulas*. 3<sup>rd</sup>. Ed. Mc Graw – Hill book Co.
- Metwally, K. A. 2010. Study the effect of some operational Factors on hammer mill. AMSC thesis of Department of Agricultural Engineering, Faculty of Agriculture, Zagazig University, Egypt.
- Odigboh, E. U. 1997. Machines for crop production. In: Stout BA, editor. *Handbook of agricultural engineering-plant production engineering*. American Society of Agricultural Engineers.
- Skoch, E. R., K. C. Behnke, C. W. Deyoe and S. F. Binder. 1981. The effect of steam-conditioning rate on the pelleting process. *Animal Feed Science and Technology*, 6:83–90.
- Stevens, C. A. 1987. Starch gelatinization and the influence of particle size, steam pressure and die speed on the pelleting process. Ph.D. dissertation. Manhattan, KS: Kansas State University.

## استهلاك الطاقة في تصنيع الانواع المختلفة من الاعلاف

مختار دبور، عادل بهنساوي، سمير احمد على، زكريا الحداد

قسم الهندسة الزراعية- كلية الزراعة- جامعة بنها

تهدف هذه الدراسة الى تقدير الطاقة المستهلكة في تصنيع الاعلاف المركزة للارانب ، الدواجن والمواشى وذلك من خلال تقدير الطاقة المستهلكة في المراحل المختلفة وتحديد نوعيتها. وقد اثبتت النتائج ان تصنيع العلف على هيئة مصبغات كان اكثر استهلاكاً للطاقة من تصنيع العلف المجروش حيث ان استهلاك الطاقة في تصنيع 1 كجم من علف الارانب، الدواجن والمواشى المصعب 243.55، 217.25 و 100.67 كجول فقط، على التوالي. والجدير بالذكر ان عملية كيس العلف الى مصبغات كانت اكثر العمليات استهلاكاً للطاقة في تصنيع كل الاعلاف المصبغة حيث تمثلت 80.26 ، 83.26 و 64.79% من اجمالي الطاقة المستهلكة في تصنيع الاعلاف السابق ذكرها ، بينما كانت عمليات التداول اكثر استهلاكاً للطاقة في تصنيع الاعلاف المجروشة حيث تمثلت 46.51 و 45.91% في تصنيع علف المواشى والدواجن المجروش، على التوالي.